

1.5/3.0/6.0 Gbps SATA/SAS Redriver

Check for Samples: [SN75LVCP600S](#)

FEATURES

- Single 3.3 V supply
- Suitable to receive 6.0 Gbps data over up to >40 inches (1.0 meter) of FR4 PC board
- Two-level RX and TX Equalization
 - RX → 7, 15dB
 - TX → 0, –1.3dB
- Pin-selectable SATA/SAS signaling
- Programmable squelch threshold for long channels

- Low active power and partial/slumber state support
 - 106mW TYP (Active Mode @6Gbps)
 - <11mW (when link in partial/slumber state)
- Ultra-small package for optimal placement
 - • 10-pad 2.5mm x 2.5mm QFN
- High ESD-transient protection
 - HBM: 9,000V
 - CDM: 1,500V
 - MM: 200V

APPLICATIONS

- Notebook and desktop PCs, docking stations, active cable, servers, workstations

DESCRIPTION

The SN75LVCP600S is a single channel SATA/SAS signal conditioner supporting data rates up to 6.0Gbps. The device complies with SATA physical spec rev 3.0 and SAS electrical spec 2.0. The SN75LVCP600S operates from a single 3.3V supply and has 100Ω line termination with self-biasing feature, making the device suitable for AC coupling. The inputs incorporate an OOB (out-of-band) detector, which automatically squelch the output while maintaining a stable common mode voltage compliant to SATA/SAS link.

The SN75LVCP600S handles interconnect losses at its input with selectable equalization settings that can be programmed to match loss in the channel. For data rates of 3Gbps and lower the LVCP600S equalizes signals for a span of up to 50 inches of FR4 board material. For data rates of 6Gbps, the device compensates > 40 inches of FR4 material. Rx/Tx equalization level is controlled by the setting of signal control pins EQ and DE.

The device is hot-plug capable⁽¹⁾ preventing device damage during device *hot*-insertion such as async signal plug/removal, unpowered plug/removal, powered plug/removal, or surprise plug/removal.

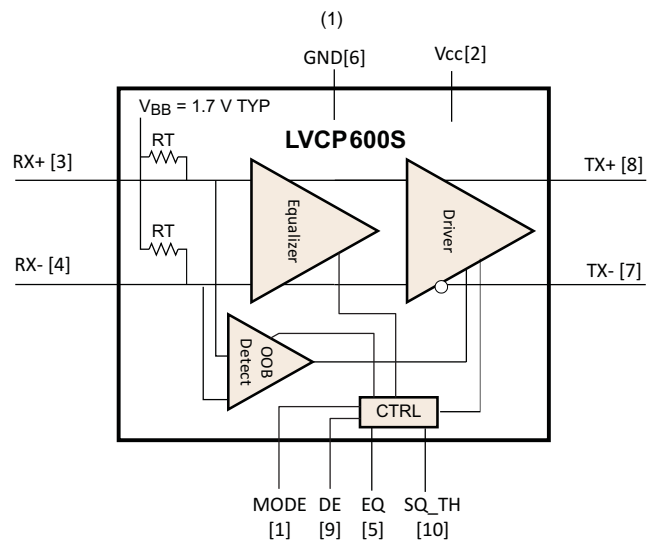

Figure 1. Data Flow Block Diagram

(1) Requires use of AC coupling capacitors at differential inputs and outputs.

Table 1. ORDERING INFORMATION⁽¹⁾

PART NUMBER	PART MARKING	PACKAGE
SN75LVCP600SDSKR	600S	10-pin DSK Reel (large)
SN75LVCP600SDSKT	600S	10-pin DSK Reel (small)

(1) For the most current package and ordering information, see the Package Option Addendum at the end of this document, or see the TI web site at www.ti.com.



Please be aware that an important notice concerning availability, standard warranty, and use in critical applications of Texas Instruments semiconductor products and disclaimers thereto appears at the end of this data sheet.



This integrated circuit can be damaged by ESD. Texas Instruments recommends that all integrated circuits be handled with appropriate precautions. Failure to observe proper handling and installation procedures can cause damage.

ESD damage can range from subtle performance degradation to complete device failure. Precision integrated circuits may be more susceptible to damage because very small parametric changes could cause the device not to meet its published specifications.

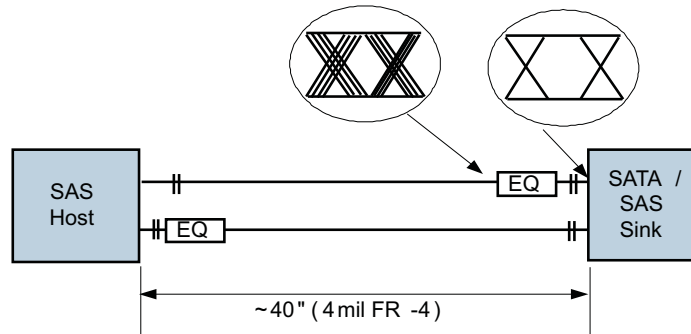

EQ = LVCP600S

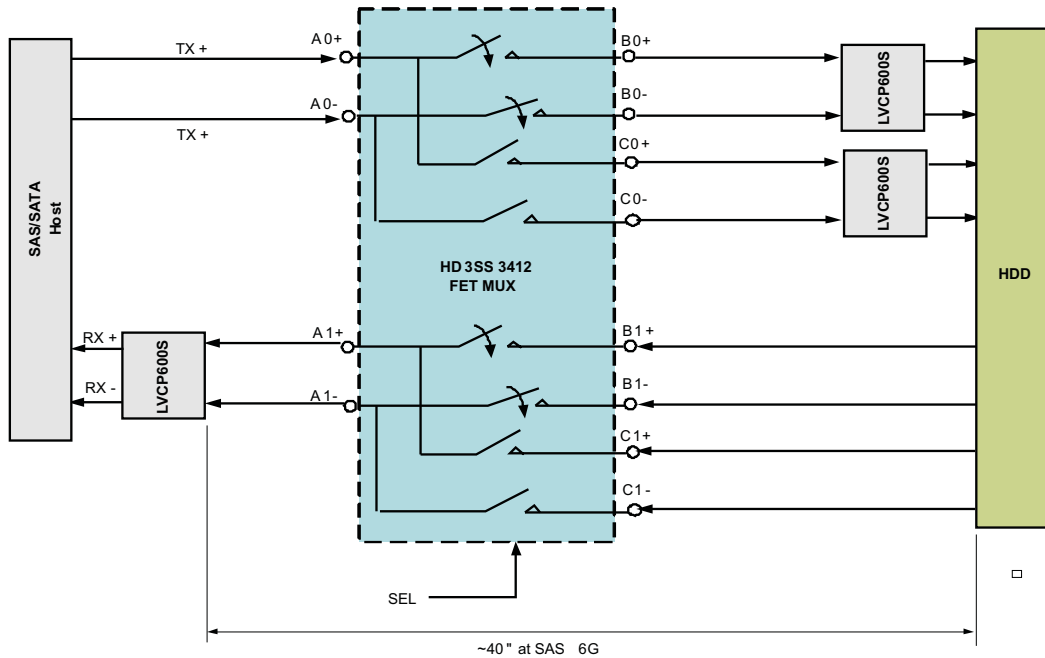
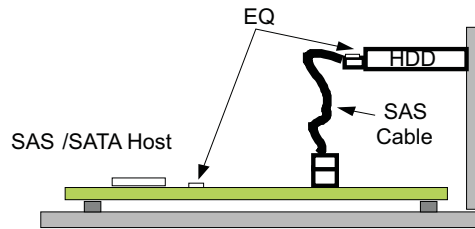
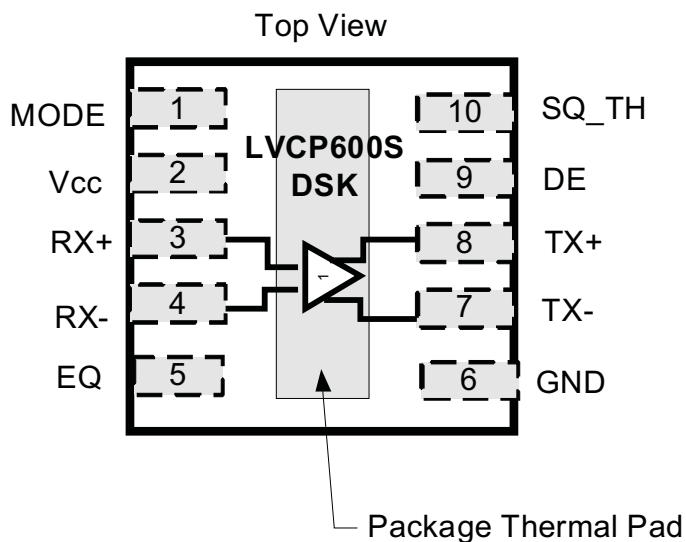

Figure 2. Typical Application

PIN ASSIGNMENTS



It is recommended to solder the package thermal pad to the ground plane for maximum thermal performance.

PIN FUNCTIONS

PIN		I/O TYPE	DESCRIPTION
NO.	NAME		
HIGH SPEED DIFFERENTIAL I/O			
3	RX+	I, CML	Non-inverting and inverting CML differential inputs. These pins are tied to an internal voltage bias by dual termination-resistor circuit.
4	RX-	I, CML	
8	TX+	I, CML	Non-inverting and inverting CML differential outputs. These pins are tied to an internal voltage bias by dual termination-resistor circuit.
7	TX-	I, CML	
CONTROL PINS			
5	EQ	I, LVCMOS	Selects equalization settings per Table 2 . Internally tied to GND.
9	DE	I, LVCMOS	Selects de-emphasis settings per Table 2 . Internally tied to GND.
1	MODE	I, LVCMOS	Selects SATA or SAS output levels per Table 2 . Internally tied to GND
10	SQ_TH	I, LVCMOS	Selects squelch threshold settings per Table 2 . Internally tied to GND
POWER			
2	V _{CC}	Power	Positive supply should be 3.3V ±10%
6	GND	Power	Supply ground

Table 2. EQ and DE Settings

Level	CONTROL PINS			
	EQ (typ) dB at 6Gbps	DE (typ) dB at 6Gbps	SQ_TH (see V _{OOB} spec)	MODE
0 (default)	7	0	Full Level (normal)	SATA
1	14	-1.3	Reduced Level (long channel)	SAS

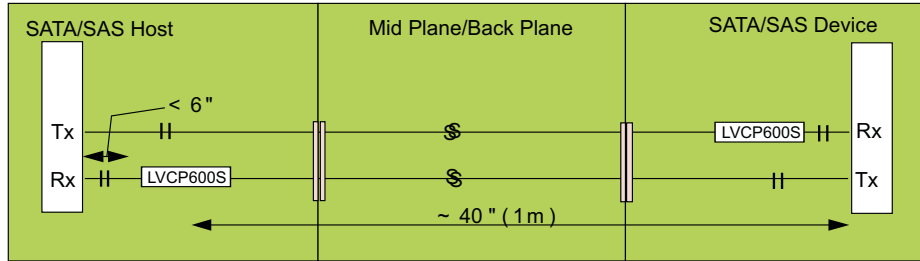

Trace lengths are suggested values based on TI spice simulations (done over programmable limits of input EQ) to meet SATA/SAS loss and jitter spec.

Actual trace length supported by the LVCP600S may be more or less than suggested values and will depend on board layout, trace widths and number of connectors used in the high speed signal path. See eye diagrams at end of datasheet for more placement guidance.

Figure 3. Trace Length Example

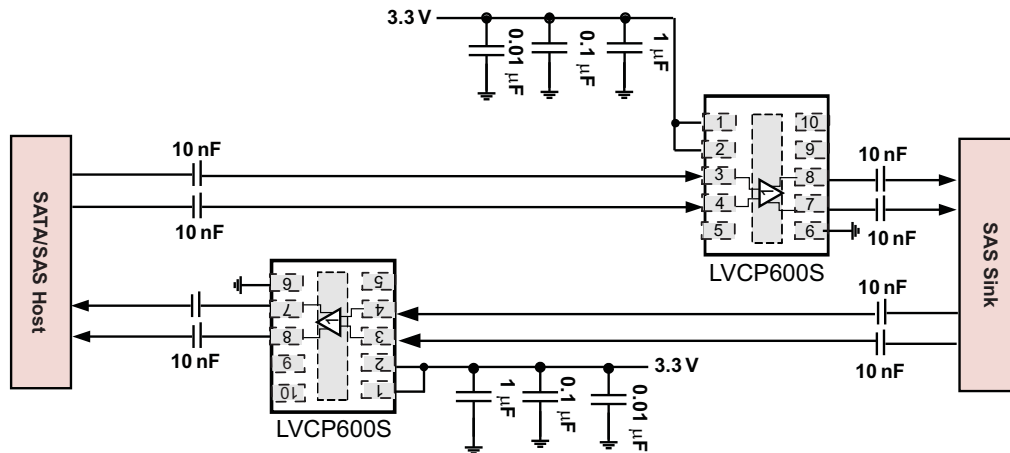

- A. Place supply capacitors close to device pin
- B. EQ selection is set at 7db, device is set in SAS mode, DE and SQ_TH at default settings
- C. Actual EQ settings depend on device placement relative to host and SATA/SAS device

Figure 4. Typical Device Implementation

OPERATION DESCRIPTION

INPUT EQUALIZATION

The SN75LVCP600S supports programmable equalization in its front stage; the equalization settings are shown in Table 2. The input equalizer is designed to recover a signal even when no eye is present at the receiver and will affectively support FR4 trace at the input anywhere from 4" to 40" at SATA 6G speed. In SAS mode, the device meets compliance point IR in a TXRX connection.

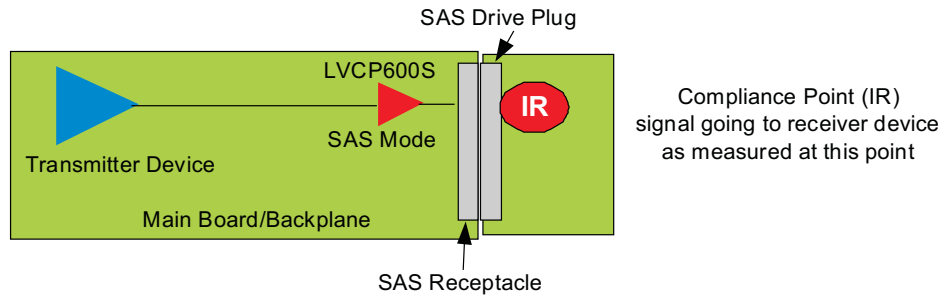

Figure 5. Compliance Point In SAS Mode

AUTO LOW POWER (ALP) MODE (see Figure 10)

As a redriver, the SN75LVCP600S does not participate in SATA or SAS link power management (PM) states. However, the redriver tracks link-power management mode (Partial and Slumber) by relying on the link differential voltage, V_{IDp-p} . The SATA/SAS link is continuously sending and receiving data even in long periods of disk inactivity by sending SYNC primitives (logical idle), except when the link enters Partial or Slumber mode. In these modes the link is in an electrical-idle state (EID). The device input squelch detector tracks EID status. When the input signal is in the electrical idle state, i.e. $V_{IDp-p} < V_{OOB_SATA}/V_{OOB_SAS}$ and stays in this state for $> 10\mu S$, the device automatically enters the low power state. In this state, the output is driven to V_{CM} and the device selectively shuts off internal circuitry to lower power consumption by ~90% of its normal operating power. While in ALP mode, the device continues to actively monitor input signal levels; when the input signal exceeds the SATA/SAS OOB upper threshold level, the device reverts to active state. Exit time from auto low power mode is $< 50ns$ (MAX).

OUT-OF-BAND (OOB) SUPPORT

The squelch detector circuit within the device enables full detection of OOB signaling as specified in the SATA and SAS specifications. Selection of squelch threshold level is made automatically based on the state of MODE pin, SATA or SAS. Squelch circuit ON/OFF time is 8ns max. While in squelch mode, outputs are held to V_{CM} .

DEVICE POWER

The SN75LVCP600S is designed to operate from a single 3.3V supply. Always practice proper power supply sequencing procedure. Apply V_{CC} first before any input signals are applied to the device. The power down sequence is in reverse order.

ABSOLUTE MAXIMUM RATINGS

over operating free-air temperature range (unless otherwise noted)⁽¹⁾

		VALUE	UNIT
Supply voltage range ⁽²⁾	V_{CC}	-0.5 to 4	V
Voltage range	Differential I/O	-0.5 to 4	V
	Control I/O	-0.5 to $V_{CC} + 0.5$	V
Electrostatic discharge	Human body model ⁽³⁾	± 9000	V
	Charged-device model ⁽⁴⁾	± 1500	V
	Machine model ⁽⁵⁾	± 200	V
Continuous power dissipation		See Dissipation Rating Table	

- (1) Stresses beyond those listed under absolute maximum ratings may cause permanent damage to the device. These are stress ratings only and functional operation of the device at these or any conditions beyond those indicated under recommended operating conditions is not implied. Exposure to absolute-maximum-rated conditions for extended periods may affect device reliability.
- (2) All voltage values, except differential voltages, are with respect to network ground terminal.
- (3) Tested in accordance with JEDEC Standard 22, Test Method A114-B.
- (4) Tested in accordance with JEDEC Standard 22, Test Method C101-A.
- (5) Tested in accordance with JEDEC Standard 22, Test Method A115-A.

THERMAL INFORMATION

THERMAL METRIC ⁽¹⁾		SN75LVCP600S	UNITS
		DSK (10) PINS	
θ_{JA}	Junction-to-ambient thermal resistance	55.7	°C/W
θ_{JcTop}	Junction-to-case (top) thermal resistance	61.9	
θ_{JB}	Junction-to-board thermal resistance	29.2	
Ψ_{JT}	Junction-to-top characterization parameter	1.0	
Ψ_{JB}	Junction-to-board characterization parameter	29.3	
θ_{JcBot}	Junction-to-case (bottom) thermal resistance	9.4	

(1) For more information about traditional and new thermal metrics, see the *IC Package Thermal Metrics* application report, [SPRA953](#).

RECOMMENDED OPERATING CONDITIONS

typical values for all parameters are at $V_{CC} = 3.3$ V and $T_A = 25^\circ\text{C}$; all temperature limits are specified by design

PARAMETER		TEST CONDITIONS	MIN	TYP	MAX	UNITS
V_{CC}	Supply voltage		3	3.3	3.6	V
$C_{COUPLING}$	Coupling capacitor			12		nF
T_A	Operating free-air temperature		-40		85	°C

ELECTRICAL CHARACTERISTICS

over recommended operating conditions (unless otherwise noted)

PARAMETER		TEST CONDITIONS	MIN	TYP	MAX	UNITS
DEVICE PARAMETERS						
I_{CCMax}	Active mode supply current	MODE/EQ/DE/SQ_TH = NC, K28.5 pattern at 6Gbps, $V_{ID} = 700mV_{pp}$, (SATA mode)		29	41	mA
		MODE/EQ/DE/SQ_TH = V_{CC} , K28.5 pattern at 6Gbps, $V_{ID} = 700mV_{pp}$, (SAS mode)		32	45	
I_{CCPS}	Auto power save mode I_{CC}	When auto low power conditions are met		3.3	5.0	mA
	Maximum data rate				6.0	Gbps
t_{PDelay}	Propagation delay	Measured using K28.5 pattern, See Figure 8		280	330	ps
AutoLP _{ENTRY}	Auto low power entry time	Electrical idle at input, See Figure 10		11	20	μs
AutoLP _{EXIT}	Auto low power exit time	After first signal activity, See Figure 10		30	40	ns

ELECTRICAL CHARACTERISTICS (continued)

over recommended operating conditions (unless otherwise noted)

PARAMETER		TEST CONDITIONS	MIN	TYP	MAX	UNITS
OOB						
V _{OOB_SAS}	Input OOB threshold (output squelched below this level)	F = 750MHz; SQ_TH=0, MODE = 1 Measured at receiver pin	88	112	131	mV _{pp}
		F = 750MHz; SQ_TH=1, MODE = 1 Measured at receiver pin	67	85	100	
V _{OOB_SATA}	Input OOB threshold (output squelched below this level)	F = 750MHz; SQ_TH=0, MODE = 0 Measured at receiver pin	40	66	86	
		F = 750MHz; SQ_TH=1, MODE = 0 Measured at receiver pin	35	56	72	
D _{VdiffOOB}	OOB differential delta				25	mV
D _{VCMOOB}	OOB common-mode delta				50	mV
t _{OOB1}	OOB mode enter	See Figure 9		3	8	ns
t _{OOB2}	OOB mode exit	See Figure 9		3	8	ns
CONTROL LOGIC						
V _{IH}	High-level input voltage	For all control pins	1.4			V
V _{IL}	Low-level input voltage				0.5	V
V _{INHYS}	Input hysteresis			115		mV
I _{IH}	High-level input current	MODE, SQ_TH = V _{CC}			30	μA
		EQ, DE = V _{CC}			20	
I _{IL}	Low-level input current	MODE, SQ_TH = GND	-30			
		EQ, DE = GND	-10			
RECEIVER AC/DC						
Z _{DIFFRX}	Differential input impedance		85	100	115	Ω
Z _{SERX}	Single-ended input impedance		40			Ω
V _{CMRX}	Common-mode voltage			1.7		V
R _{LDiffRX}	Differential mode return loss (RL)	f = 150MHz–300MHz	18	26		dB
		f = 300MHz–600MHz	14	23		
		f = 600MHz–1.2GHz	10	17		
		f = 1.2GHz–2.4GHz	8	14		
		f = 2.4GHz–3.0GHz	3	13		
R _{XDiffRLSlope}	Differential mode RL slope	f = 300MHz–6.0GHz		-13		dB/dec
R _{LCMRX}	Common-mode return loss	f = 150MHz–300MHz	5	10		dB
		f = 300MHz–600MHz	5	18		
		f = 600MHz–1.2GHz	2	16		
		f = 1.2GHz–2.4GHz	1	12		
		f = 2.4GHz–3.0GHz	1	12		
V _{diffRX}	Differential input voltage PP	MODE = 1, f = 1.5GHz and 3.0GHz	275		1600	mV/ppd
		MODE = 0, f = 1.5GHz and 3.0GHz	225		1600	
I _{B RX}	Impedance balance	f = 150MHz–300MHz	30	47		dB
		f = 300MHz–600MHz	30	40		
		f = 600MHz–1.2GHz	20	34		
		f = 1.2GHz–2.4GHz	10	28		
		f = 2.4GHz–3.0GHz	10	24		
		f = 3.0GHz–5.0GHz	4	22		
T _{20-80RX}	Rise/fall time	Rise times and fall times measured between 20% and 80% of the signal. SATA/SAS 6 Gbps speed measured 1" from device pin	62		75	ps

ELECTRICAL CHARACTERISTICS (continued)

over recommended operating conditions (unless otherwise noted)

PARAMETER		TEST CONDITIONS	MIN	TYP	MAX	UNITS
T_{skewRX}	Differential skew	Difference between the single-ended mid-point of the RX+ signal rising/falling edge, and the single-ended mid-point of the RX- signal falling/rising edge			30	ps
TRANSMITTER AC/DC						
Z_{diffTX}	Pair differential impedance		85	100	122	Ω
Z_{SETX}	Single-ended input impedance		40			Ω
V_{TXtrans}	Sequencing transient voltage	Transient voltages on the serial data bus during power sequencing (lab load)	-1.2	0	1.2	V
RL_{DiffTX}	Differential mode return loss	$f = 150\text{MHz} - 300\text{MHz}$	13	22		dB
		$f = 300\text{MHz} - 600\text{MHz}$	8	21		
		$f = 600\text{MHz} - 1.2\text{GHz}$	6	20		
		$f = 1.2\text{GHz} - 2.4\text{GHz}$	6	17		
		$f = 2.4\text{GHz} - 3.0\text{GHz}$	3	17		
$TX_{\text{DiffRLSlope}}$	Differential mode RL slope	$f = 300\text{MHz} - 3.0\text{GHz}$		-13		dB/dec
RL_{CMTX}	Common-mode return loss	$f = 150\text{MHz} - 300\text{MHz}$	5	19		dB
		$f = 300\text{MHz} - 600\text{MHz}$	5	16		
		$f = 600\text{MHz} - 1.2\text{GHz}$	2	11		
		$f = 1.2\text{GHz} - 2.4\text{GHz}$	1	9		
		$f = 2.4\text{GHz} - 3.0\text{GHz}$	1	10		
IB_{TX}	Impedance balance	$f = 150\text{MHz} - 300\text{MHz}$	30	43		dB
		$f = 300\text{MHz} - 600\text{MHz}$	30	40		
		$f = 600\text{MHz} - 1.2\text{GHz}$	20	32		
		$f = 1.2\text{GHz} - 2.4\text{GHz}$	10	25		
		$f = 2.4\text{GHz} - 3.0\text{GHz}$	10	27		
		$f = 3.0\text{GHz} - 5.0\text{GHz}$	4	25		
		$f = 5.0\text{GHz} - 6.5\text{GHz}$	4	26		
$\text{Diff}V_{\text{ppTX}}$	Differential output voltage swing	DE = 1, MODE = 1 \rightarrow (SAS), $f = 3.0\text{GHz}$ (under no interconnect loss)	385	850	1300	mV/ppd
		DE = 0, MODE = 0 \rightarrow (SATA), $f = 3.0\text{GHz}$ (under no interconnect loss)	400	600	800	
DE	De-Emphasis Level	DE = 1		-1.3		dB
		DE = 0		0		
$VCM_{\text{AC_TX}}$	TX AC CM voltage	At 1.5GHz		20	50	mVppd
		At 3.0GHz		11	26	dBmv (rms)
		At 6.0GHz		13	30	
VCM_{TX}	Common-mode voltage			1.7		V
$T_{20-80\text{TX}}$	Rise/Fall time	Rise times and fall times measured between 20% and 80% of the signal. At 6Gbps SATA or SAS, under no load, measured at the pin	33	50	76	ps
T_{skewTX}	Differential skew	Difference between the single-ended mid-point of the TX+ signal rising/falling edge, and the single-ended mid-point of the TX- signal falling/rising edge, SATA or SAS mode		4	14	ps
TXR/F_{Imb}	TX rise/fall imbalance	At 3 Gbps		3	18	%
$TXAm_{\text{plmb}}$	TX amplitude imbalance			1.5	10	

ELECTRICAL CHARACTERISTICS (continued)

over recommended operating conditions (unless otherwise noted)

PARAMETER		TEST CONDITIONS	MIN	TYP	MAX	UNITS
TRANSMITTER JITTER AT CP⁽¹⁾						
3Gbps SATA mode						
T _{JTX}	Total jitter ⁽¹⁾		0.26	0.38		U _{Ipp}
DJ _{TX}	Deterministic jitter	V _{ID} = 500 mV _{pp} , UI = 333ps, K28.5 control character, EQ/DE=1	0.13	0.24		U _{Ipp}
RJ _{TX}	Residual random jitter	V _{ID} = 500 mV _{pp} , UI = 333ps, K28.7 control character, EQ/DE=1	1.16	1.95		ps-rms
6Gbps SATA mode						
T _{JTX}	Total jitter ⁽¹⁾		0.37	0.61		U _{Ipp}
DJ _{TX}	Deterministic jitter	V _{ID} = 500 mV _{pp} , UI = 167ps, K28.5 control character, EQ/DE=1	0.12	0.32		U _{Ipp}
RJ _{TX}	Residual random jitter	V _{ID} = 500 mV _{pp} , UI = 167ps, K28.7 control character, EQ/DE=1	1.15	2.2		ps-rms
3Gbps SAS mode						
T _{JTX}	Total jitter ⁽¹⁾		0.25	0.37		U _{Ipp}
DJ _{TX}	Deterministic jitter	V _{ID} = 500 mV _{pp} , UI = 333ps, K28.5 control character, EQ/DE=1	0.12	0.23		U _{Ipp}
RJ _{TX}	Residual random jitter	V _{ID} = 500 mV _{pp} , UI = 333ps, K28.7 control character, EQ/DE=1	1.11	2.0		ps-rms
6Gbps SAS mode						
T _{JTX}	Total jitter ⁽¹⁾		0.35	0.57		U _{Ipp}
DJ _{TX}	Deterministic jitter	V _{ID} = 500 mV _{pp} , UI = 167ps, K28.5 control character, EQ/DE=1	0.10	0.29		U _{Ipp}
RJ _{TX}	Residual random jitter	V _{ID} = 500 mV _{pp} , UI = 167ps, K28.7 control character, EQ/DE=1	1.10	2.14		ps-rms

(1) $T_J = (14.1 \times RJ_{SD} + DJ)$ where RJ_{SD} is one standard deviation value of RJ Gaussian distribution. Jitter measurement is at the CP connector and includes jitter generated at the package connection on the printed circuit board, and at the board interconnect as shown in Figure 6.

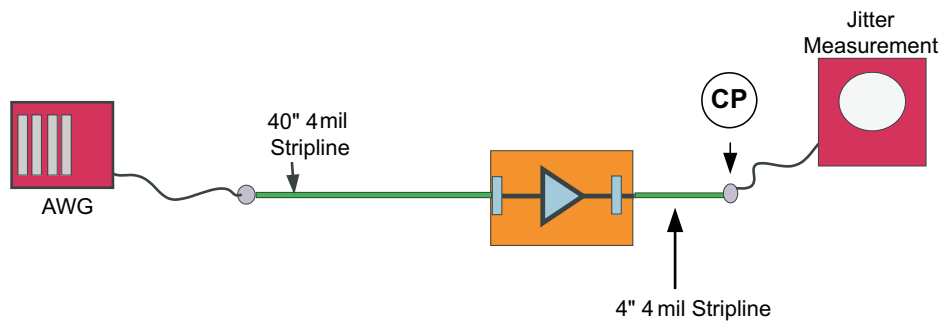

Figure 6. Jitter Measurement Test Condition

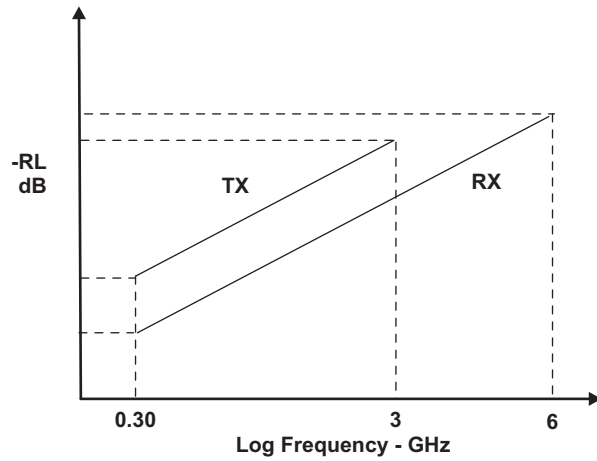

Figure 7. TX, RX Differential Return Loss Limits

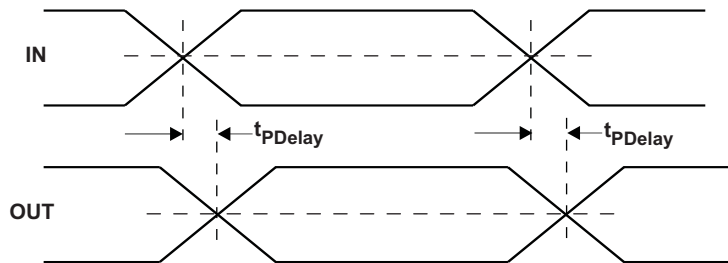

Figure 8. Propagation Delay Timing Diagram

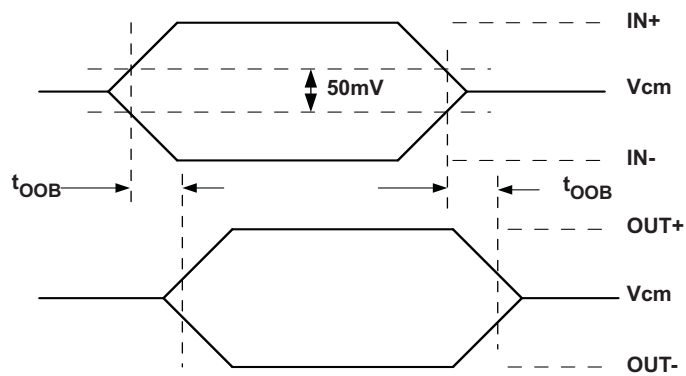

Figure 9. OOB Enter and Exit Timing

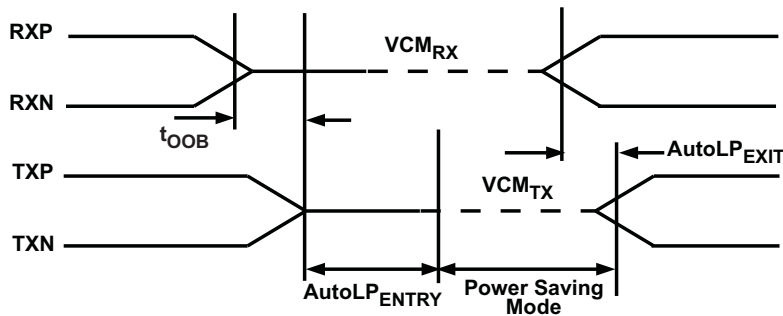
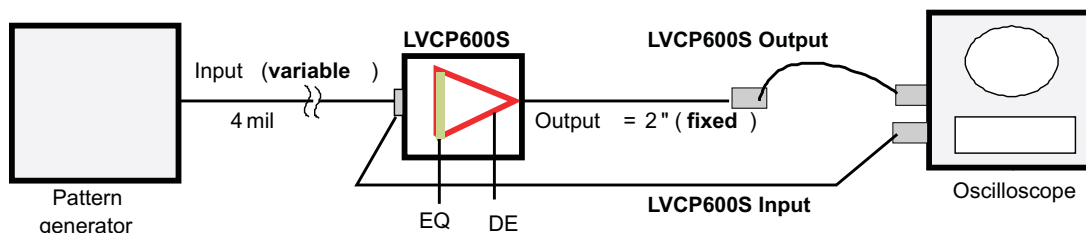

Figure 10. Auto Low Power Mode Entry and Exit Timing

TYPICAL EYE DIAGRAMS AND PERFORMANCE CURVES



- A. $V_{CC} = 3.3V$; INPUT = K28.5 pattern at 1.5Gbps; 3.0Gbps and 6.0 Gbps; $V_{ID} = 1000mV_{pp}$; TEMP = 25°C; TRACE WIDTH = 4mil

Figure 11. Eye Diagram Measurement Setup for LVCP600S

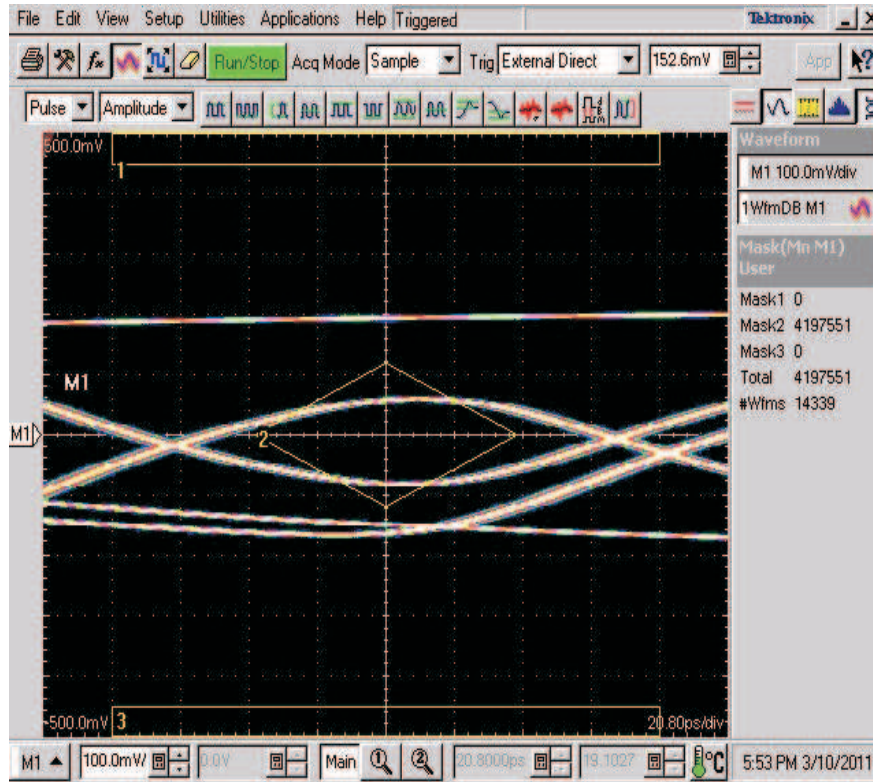

Figure 12. SATA 6.0 Gbps Signal After 16” , Input of LVCP600S (MODE=0)

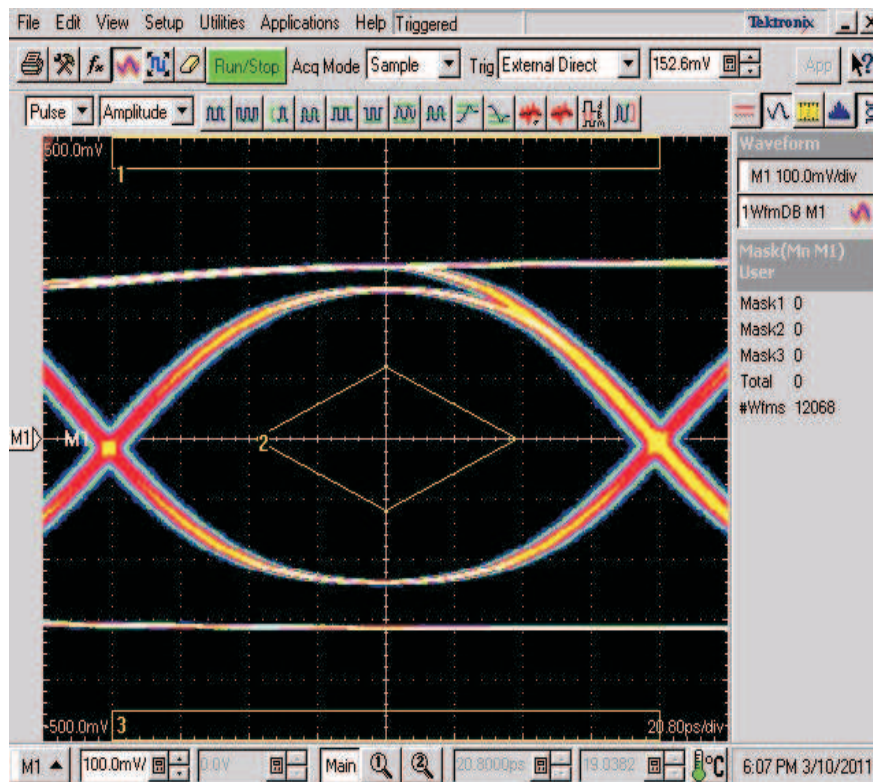

Figure 13. SATA 6.0 Gbps DE= 0, EQ = 1, at Output = 2” after Equalizing (MODE=0)

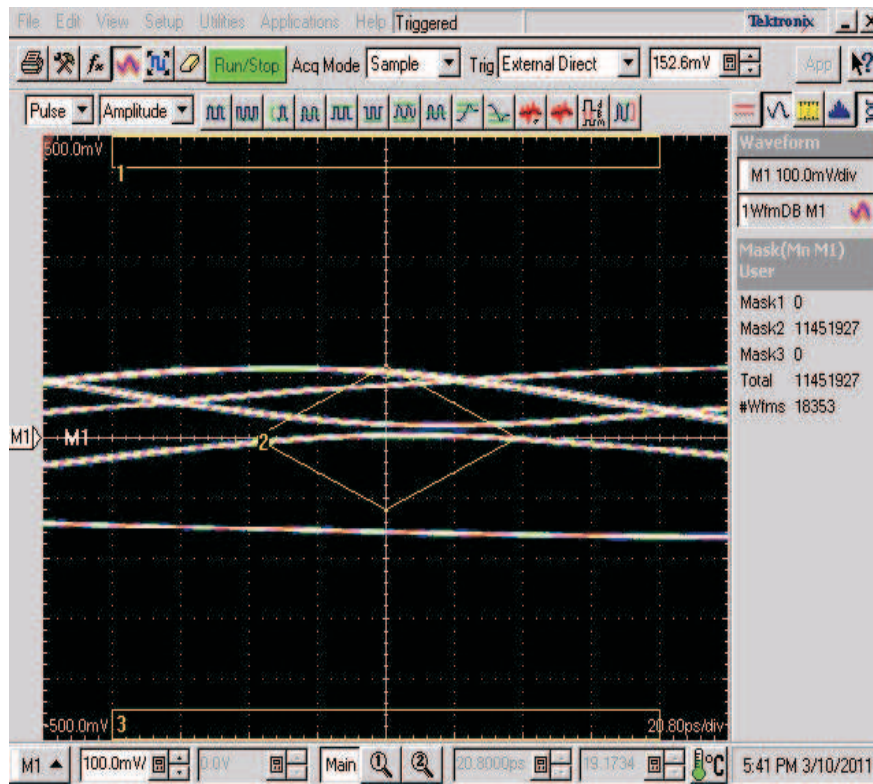

Figure 14. SATA 6.0 Gbps signal after 32” at Input of LVCP600S (MODE=0)

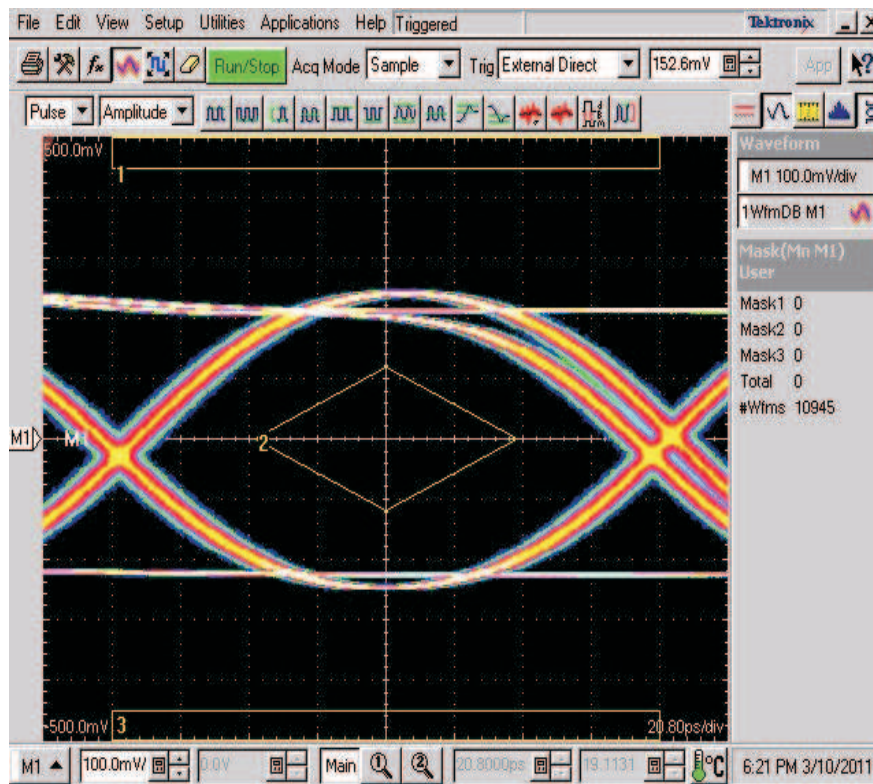

Figure 15. SATA 6.0 Gbps DE= 0, EQ = 1, at Output = 2” after Equalizing (MODE=0)

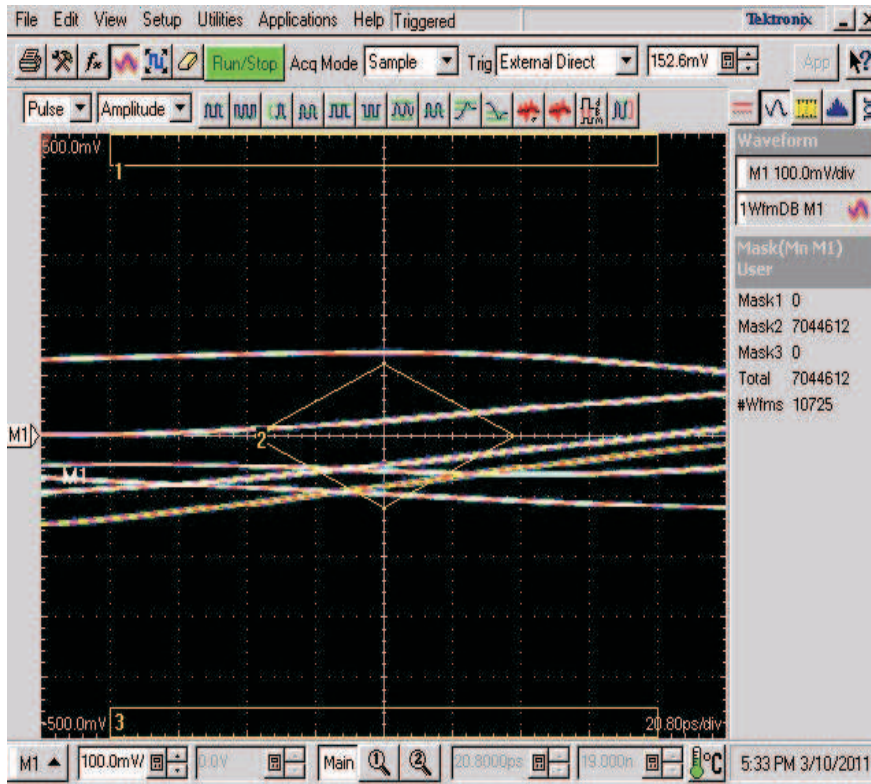

Figure 16. SATA 6.0 Gbps signal after 40” at Input of LVCP600S (MODE=0)

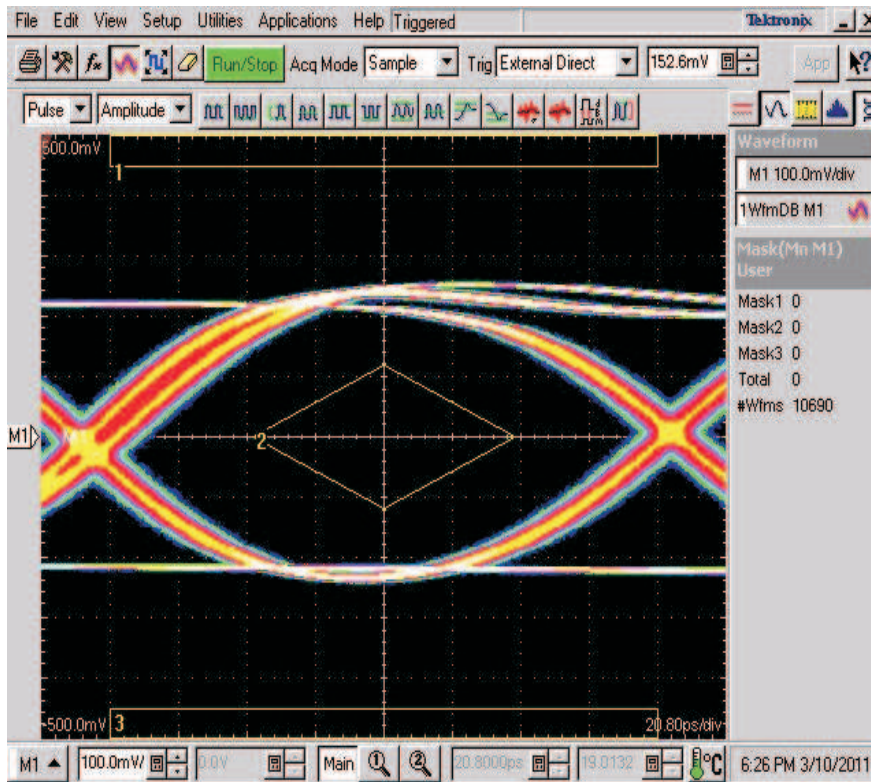

Figure 17. SATA 6.0 Gbps DE= 1, EQ = 1, at Output = 2” after Equalizing (MODE=0)

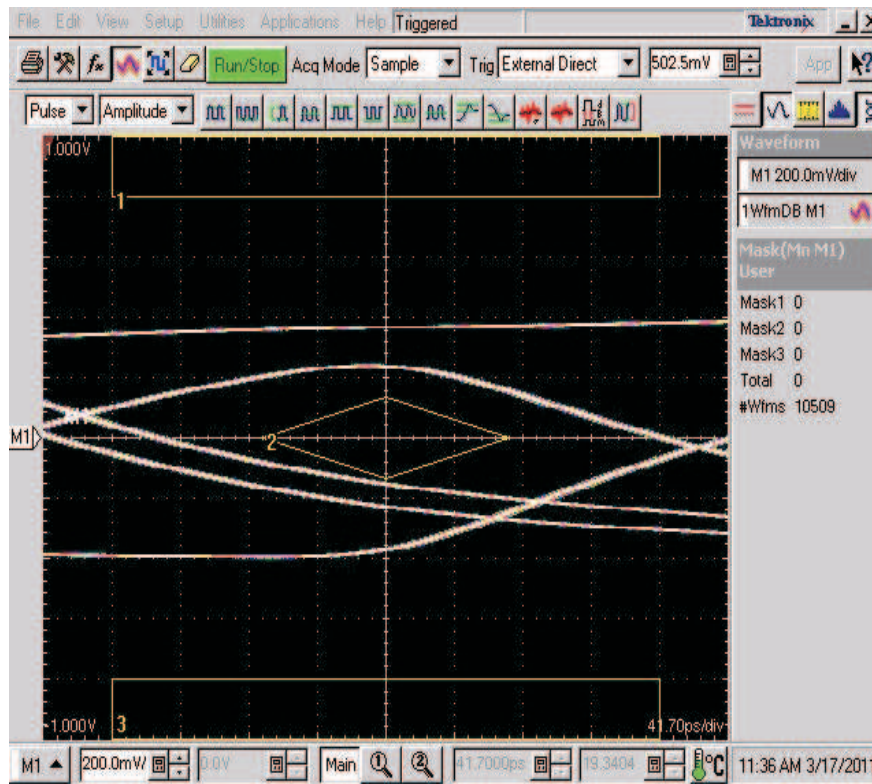

Figure 18. SAS 3.0 Gbps signal after 32" at Input of LVCP600S (MODE=1)

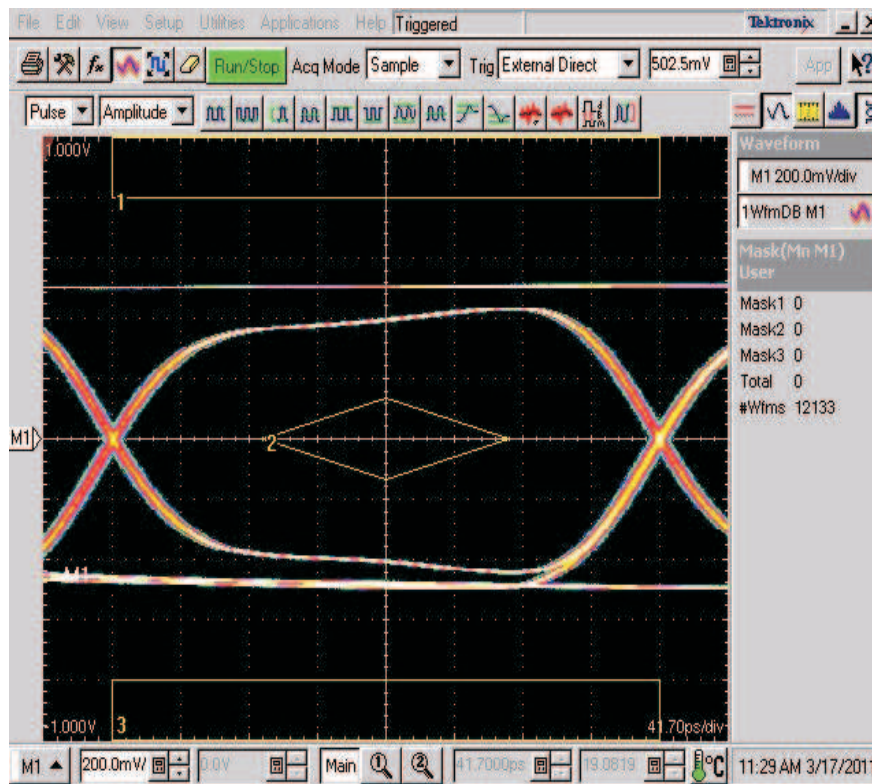

Figure 19. SAS 3.0 Gbps DE= 0, EQ = 1, at Output = 2" after Equalizing (MODE=1)

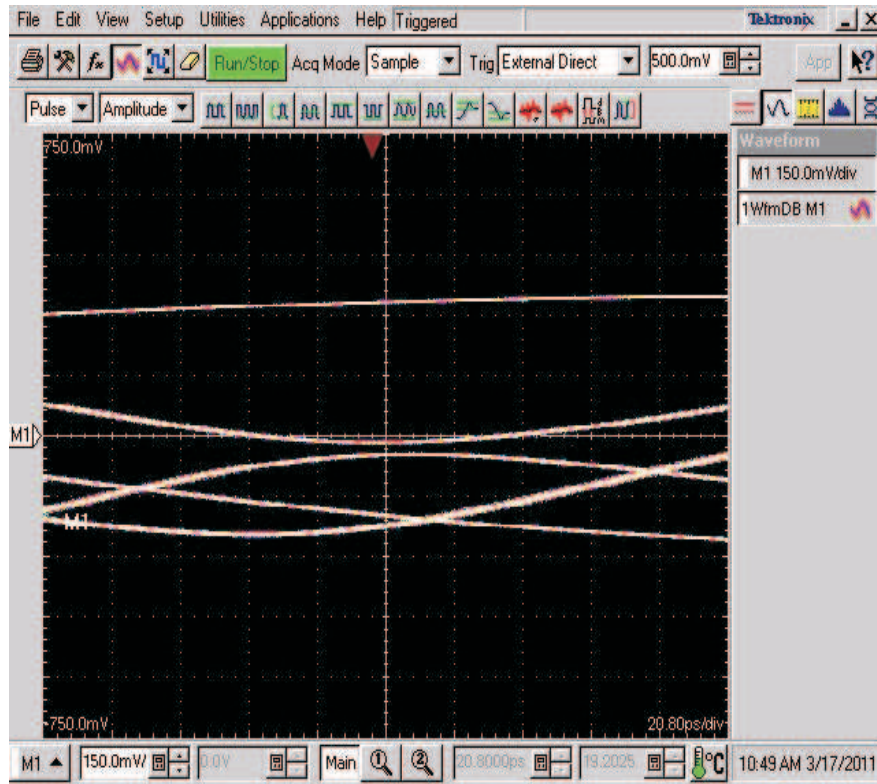

Figure 20. SAS 6.0 Gbps signal after 32” at Input of LVCP600S (MODE=1)

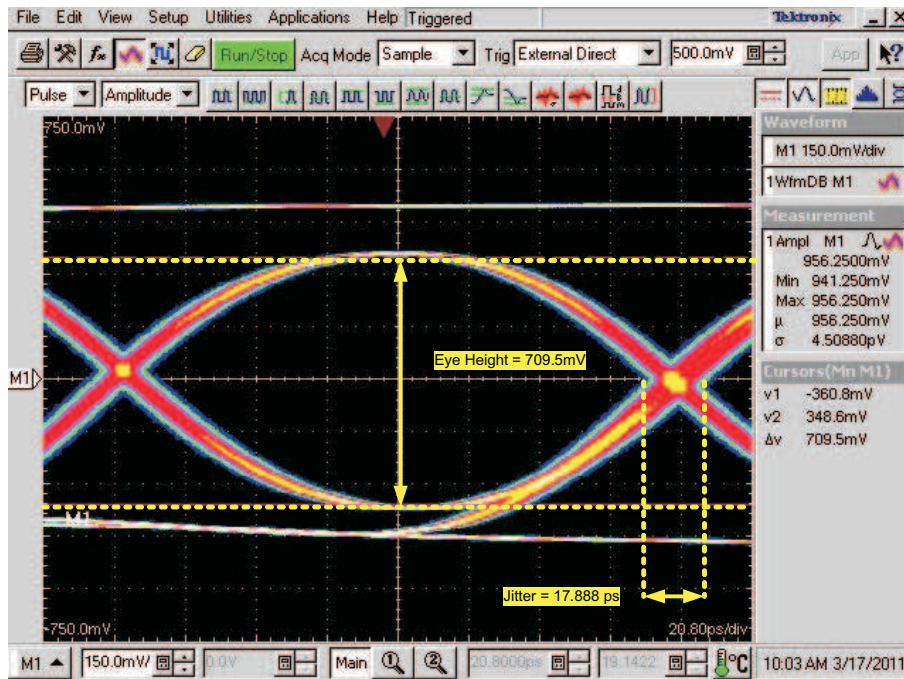

Figure 21. SAS 6.0 Gbps DE= 0, EQ = 1, at Output = 2” after Equalizing (MODE=1)

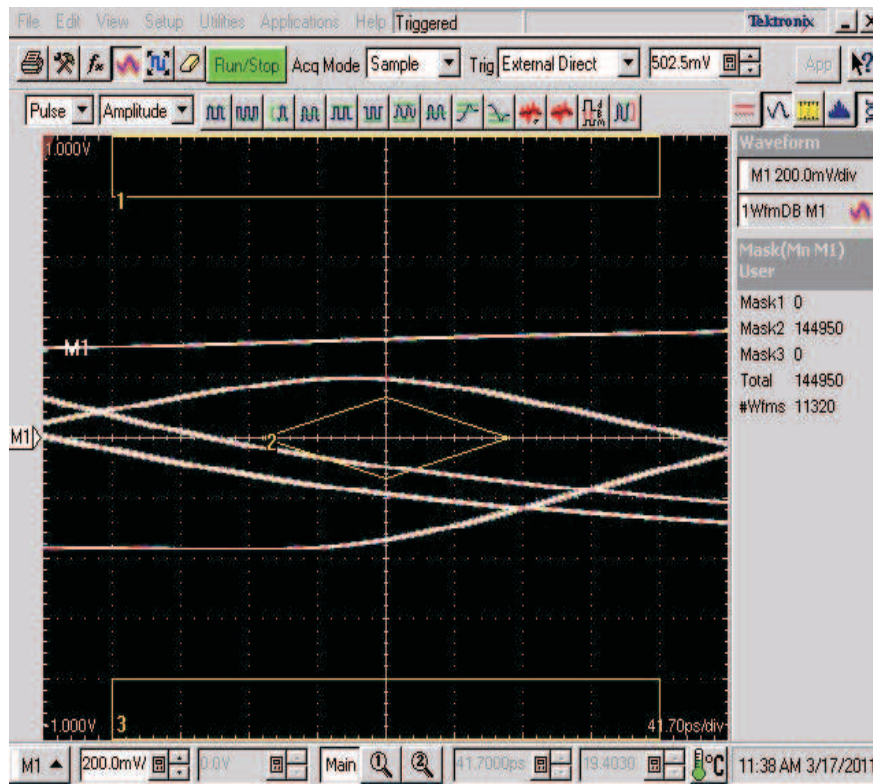

Figure 22. SAS 3.0 Gbps signal after 40" at Input of LVCP600S (MODE=1)

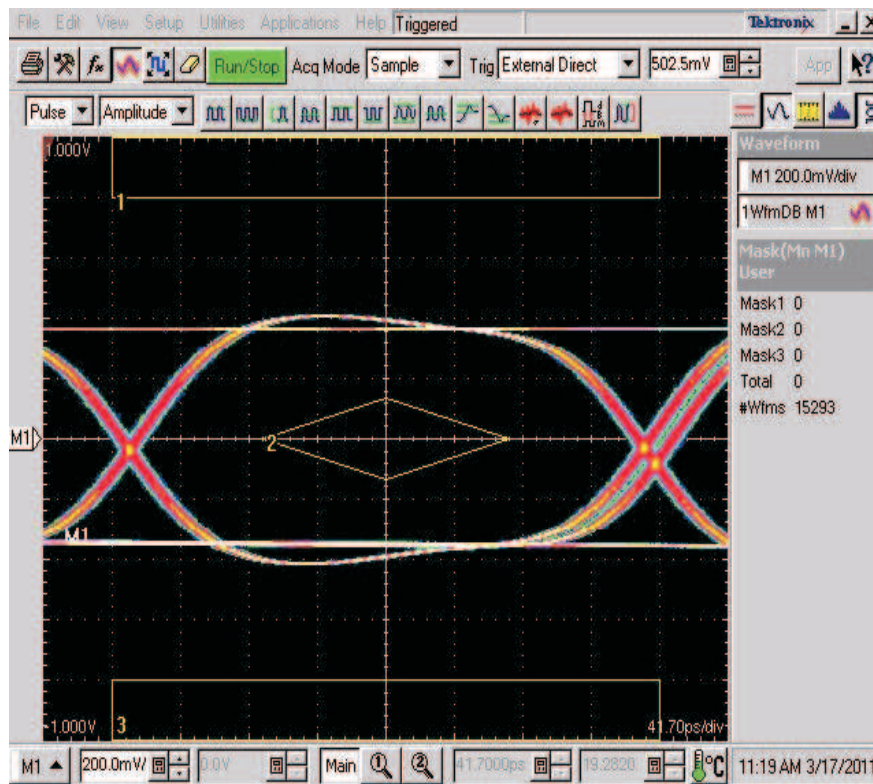

Figure 23. SAS 3.0 Gbps DE= 1, EQ = 1, at Output = 2" after Equalizing (MODE=1)

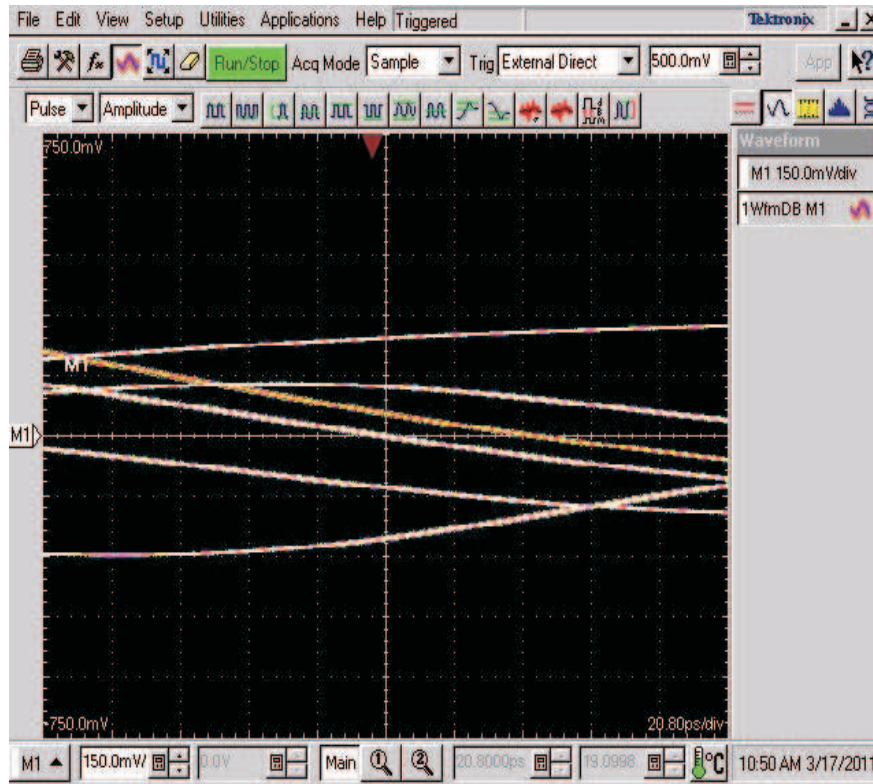

Figure 24. SAS 6.0 Gbps signal after 40" at Input of LVCP600S (MODE=1)

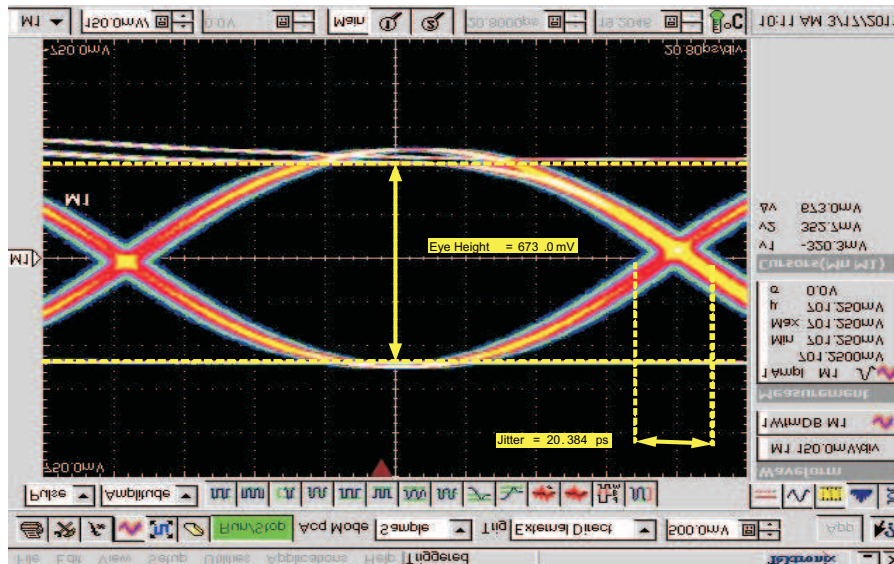

Figure 25. SAS 6.0 Gbps DE= 1, EQ = 1, at Output = 2" after Equalizing (MODE=1)

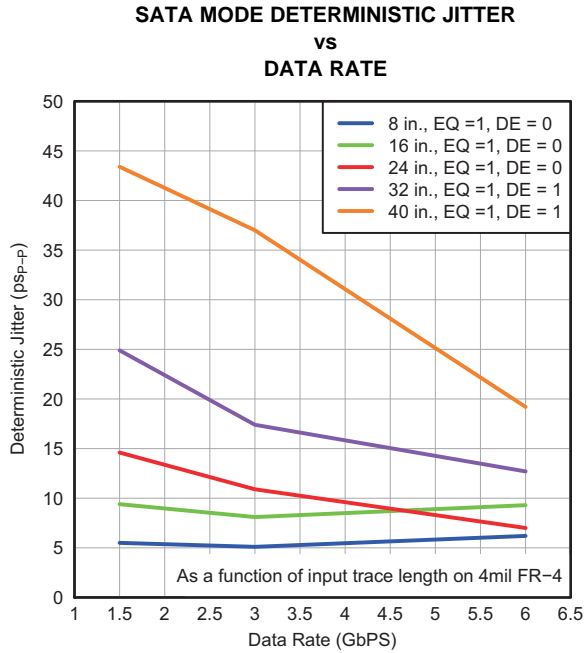

Figure 26.

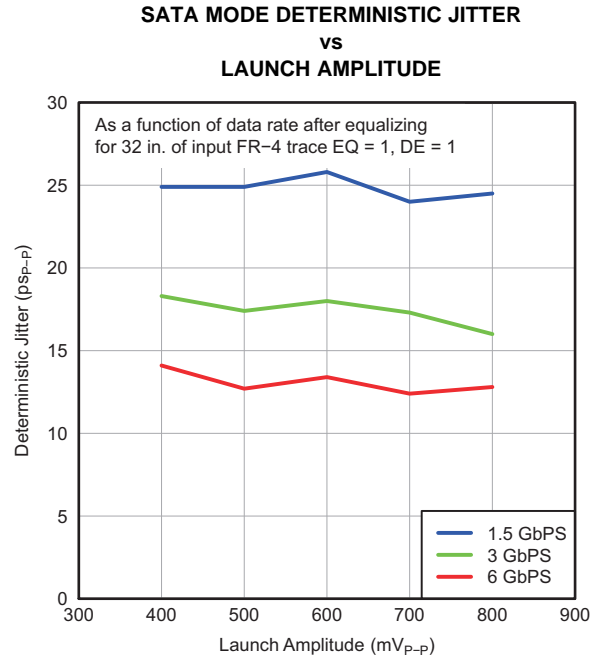

Figure 27.

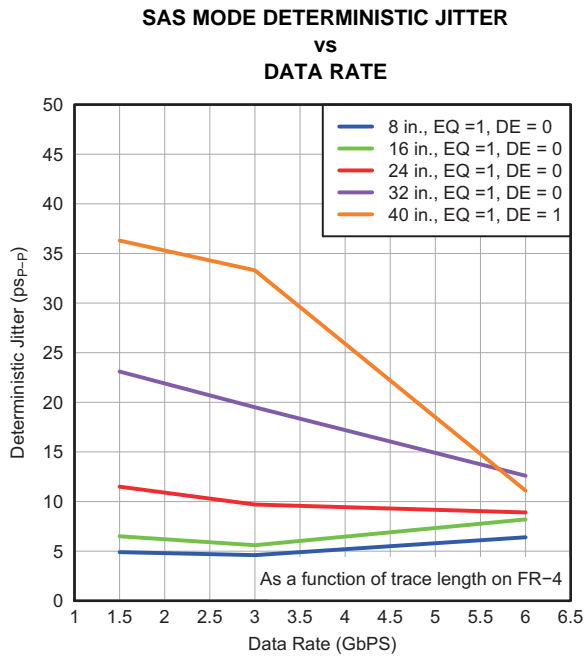

Figure 28.

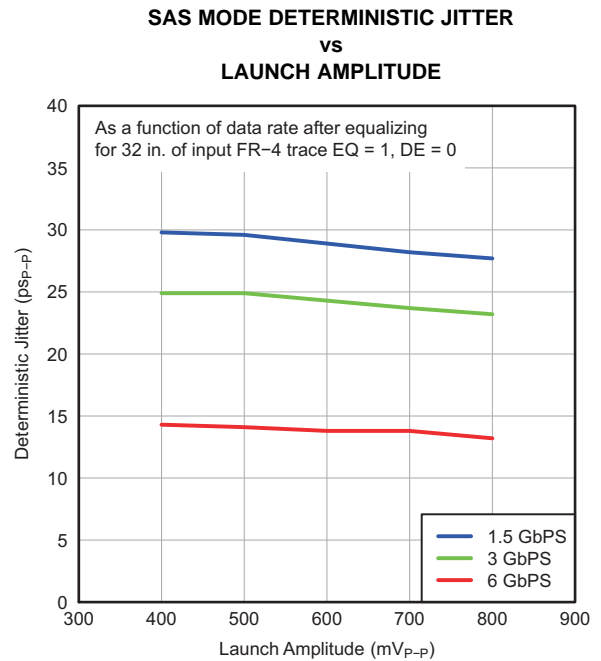

Figure 29.

PACKAGING INFORMATION

Orderable Device	Status ⁽¹⁾	Package Type	Package Drawing	Pins	Package Qty	Eco Plan ⁽²⁾	Lead/ Ball Finish	MSL Peak Temp ⁽³⁾	Samples (Requires Login)
SN75LVCP600SDSKR	ACTIVE	SON	DSK	10	3000	Green (RoHS & no Sb/Br)	CU NIPDAU	Level-2-260C-1 YEAR	
SN75LVCP600SDSKT	ACTIVE	SON	DSK	10	250	Green (RoHS & no Sb/Br)	CU NIPDAU	Level-2-260C-1 YEAR	

⁽¹⁾ The marketing status values are defined as follows:

ACTIVE: Product device recommended for new designs.

LIFEBUY: TI has announced that the device will be discontinued, and a lifetime-buy period is in effect.

NRND: Not recommended for new designs. Device is in production to support existing customers, but TI does not recommend using this part in a new design.

PREVIEW: Device has been announced but is not in production. Samples may or may not be available.

OBSOLETE: TI has discontinued the production of the device.

⁽²⁾ Eco Plan - The planned eco-friendly classification: Pb-Free (RoHS), Pb-Free (RoHS Exempt), or Green (RoHS & no Sb/Br) - please check <http://www.ti.com/productcontent> for the latest availability information and additional product content details.

TBD: The Pb-Free/Green conversion plan has not been defined.

Pb-Free (RoHS): TI's terms "Lead-Free" or "Pb-Free" mean semiconductor products that are compatible with the current RoHS requirements for all 6 substances, including the requirement that lead not exceed 0.1% by weight in homogeneous materials. Where designed to be soldered at high temperatures, TI Pb-Free products are suitable for use in specified lead-free processes.

Pb-Free (RoHS Exempt): This component has a RoHS exemption for either 1) lead-based flip-chip solder bumps used between the die and package, or 2) lead-based die adhesive used between the die and leadframe. The component is otherwise considered Pb-Free (RoHS compatible) as defined above.

Green (RoHS & no Sb/Br): TI defines "Green" to mean Pb-Free (RoHS compatible), and free of Bromine (Br) and Antimony (Sb) based flame retardants (Br or Sb do not exceed 0.1% by weight in homogeneous material)

⁽³⁾ MSL, Peak Temp. -- The Moisture Sensitivity Level rating according to the JEDEC industry standard classifications, and peak solder temperature.

Important Information and Disclaimer: The information provided on this page represents TI's knowledge and belief as of the date that it is provided. TI bases its knowledge and belief on information provided by third parties, and makes no representation or warranty as to the accuracy of such information. Efforts are underway to better integrate information from third parties. TI has taken and continues to take reasonable steps to provide representative and accurate information but may not have conducted destructive testing or chemical analysis on incoming materials and chemicals. TI and TI suppliers consider certain information to be proprietary, and thus CAS numbers and other limited information may not be available for release.

In no event shall TI's liability arising out of such information exceed the total purchase price of the TI part(s) at issue in this document sold by TI to Customer on an annual basis.

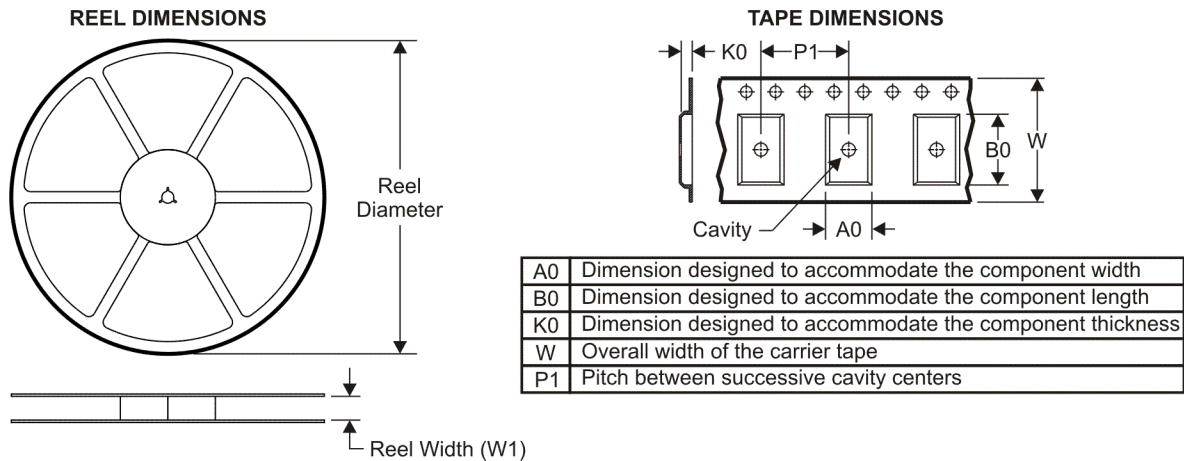
TAPE AND REEL INFORMATION

QUADRANT ASSIGNMENTS FOR PIN 1 ORIENTATION IN TAPE

*All dimensions are nominal

Device	Package Type	Package Drawing	Pins	SPQ	Reel Diameter (mm)	Reel Width W1 (mm)	A0 (mm)	B0 (mm)	K0 (mm)	P1 (mm)	W (mm)	Pin1 Quadrant
SN75LVCP600SDSKR	SON	DSK	10	3000	180.0	8.4	2.8	2.8	1.0	4.0	8.0	Q2
SN75LVCP600SDSKT	SON	DSK	10	250	180.0	8.4	2.8	2.8	1.0	4.0	8.0	Q2

TAPE AND REEL BOX DIMENSIONS



*All dimensions are nominal

Device	Package Type	Package Drawing	Pins	SPQ	Length (mm)	Width (mm)	Height (mm)
SN75LVCP600SDSKR	SON	DSK	10	3000	190.5	212.7	31.8
SN75LVCP600SDSKT	SON	DSK	10	250	190.5	212.7	31.8

DSK (S-PDSO-N10)

PLASTIC QUAD FLATPACK

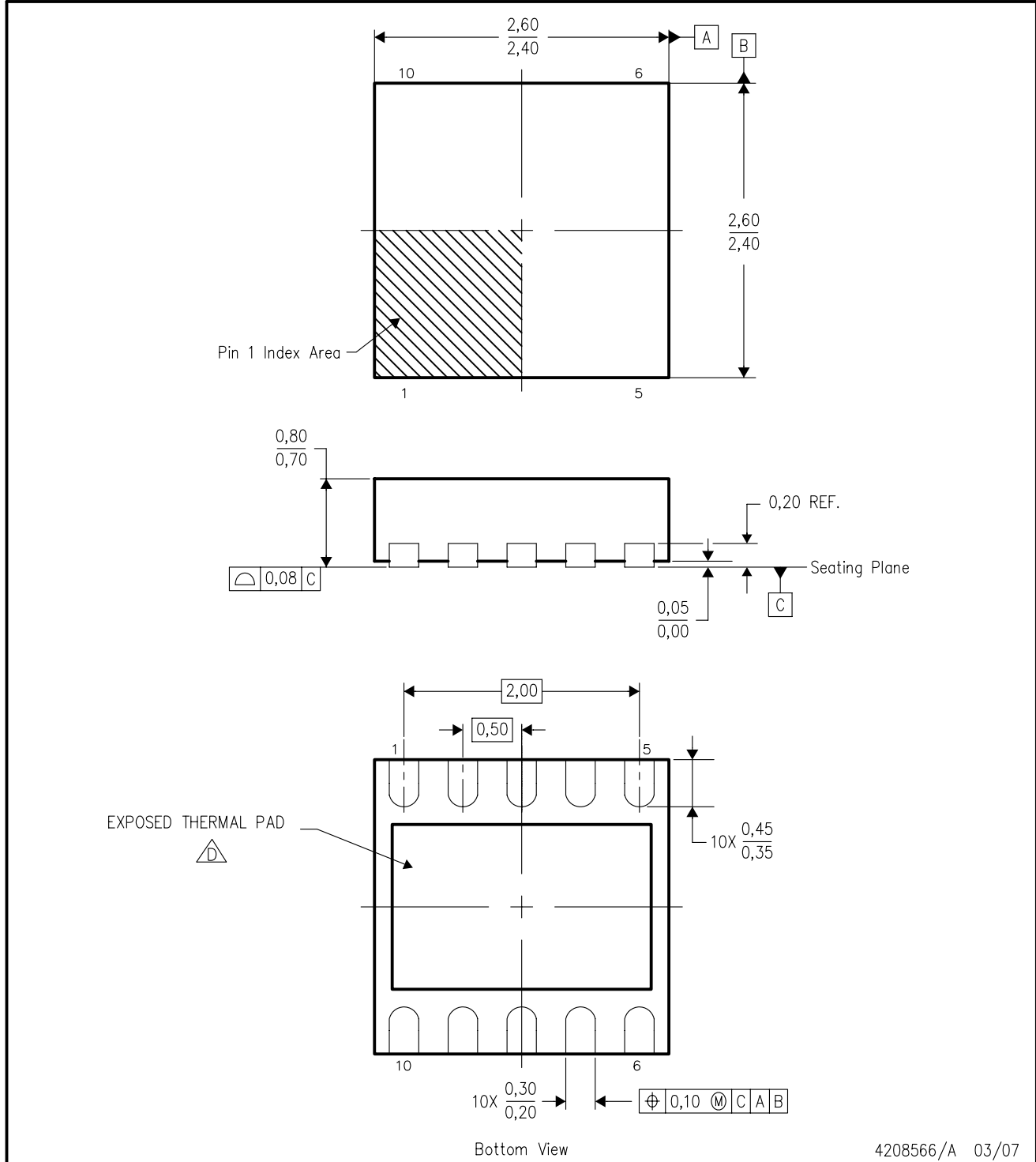

4208566/A 03/07

- NOTES:
- A. All linear dimensions are in millimeters. Dimensioning and tolerancing per ASME Y14.5M-1994.
 - B. This drawing is subject to change without notice.
 - C. Small Outline No-Lead (SON) package configuration.
 -  The package thermal pad must be soldered to the board for thermal and mechanical performance. See the Product Data Sheet for details regarding the exposed thermal pad dimensions.

THERMAL PAD MECHANICAL DATA

DSK (R-PWSON-N10)

PLASTIC SMALL OUTLINE NO-LEAD

THERMAL INFORMATION

This package incorporates an exposed thermal pad that is designed to be attached directly to an external heatsink. The thermal pad must be soldered directly to the printed circuit board (PCB). After soldering, the PCB can be used as a heatsink. In addition, through the use of thermal vias, the thermal pad can be attached directly to the appropriate copper plane shown in the electrical schematic for the device, or alternatively, can be attached to a special heatsink structure designed into the PCB. This design optimizes the heat transfer from the integrated circuit (IC).

For information on the Quad Flatpack No-Lead (QFN) package and its advantages, refer to Application Report, QFN/SON PCB Attachment, Texas Instruments Literature No. SLUA271. This document is available at www.ti.com.

The exposed thermal pad dimensions for this package are shown in the following illustration.

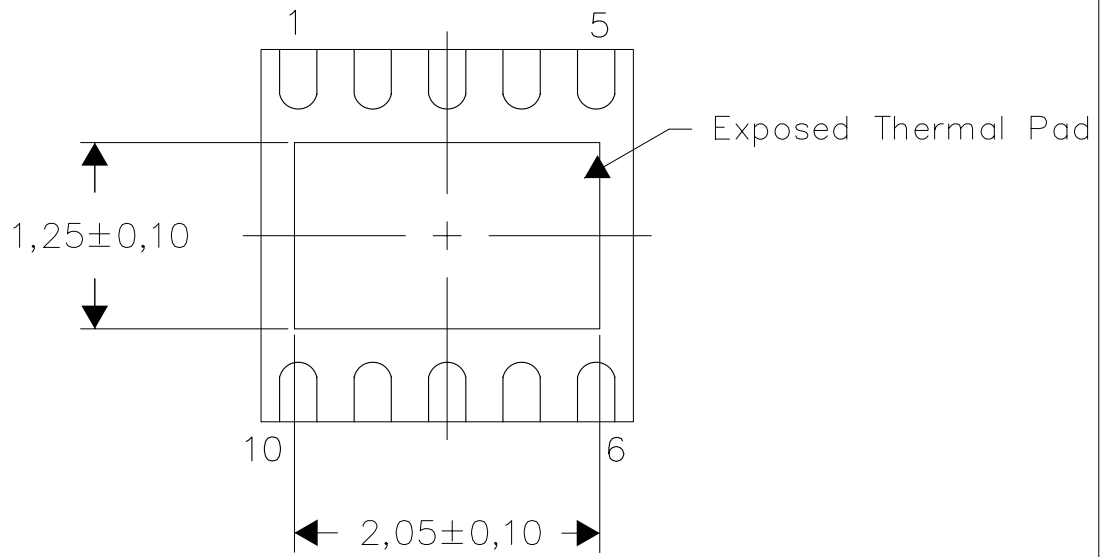

Bottom View

Exposed Thermal Pad Dimensions

4208579-3/D 10/10

NOTE: A. All linear dimensions are in millimeters

IMPORTANT NOTICE

Texas Instruments Incorporated and its subsidiaries (TI) reserve the right to make corrections, modifications, enhancements, improvements, and other changes to its products and services at any time and to discontinue any product or service without notice. Customers should obtain the latest relevant information before placing orders and should verify that such information is current and complete. All products are sold subject to TI's terms and conditions of sale supplied at the time of order acknowledgment.

TI warrants performance of its hardware products to the specifications applicable at the time of sale in accordance with TI's standard warranty. Testing and other quality control techniques are used to the extent TI deems necessary to support this warranty. Except where mandated by government requirements, testing of all parameters of each product is not necessarily performed.

TI assumes no liability for applications assistance or customer product design. Customers are responsible for their products and applications using TI components. To minimize the risks associated with customer products and applications, customers should provide adequate design and operating safeguards.

TI does not warrant or represent that any license, either express or implied, is granted under any TI patent right, copyright, mask work right, or other TI intellectual property right relating to any combination, machine, or process in which TI products or services are used. Information published by TI regarding third-party products or services does not constitute a license from TI to use such products or services or a warranty or endorsement thereof. Use of such information may require a license from a third party under the patents or other intellectual property of the third party, or a license from TI under the patents or other intellectual property of TI.

Reproduction of TI information in TI data books or data sheets is permissible only if reproduction is without alteration and is accompanied by all associated warranties, conditions, limitations, and notices. Reproduction of this information with alteration is an unfair and deceptive business practice. TI is not responsible or liable for such altered documentation. Information of third parties may be subject to additional restrictions.

Resale of TI products or services with statements different from or beyond the parameters stated by TI for that product or service voids all express and any implied warranties for the associated TI product or service and is an unfair and deceptive business practice. TI is not responsible or liable for any such statements.

TI products are not authorized for use in safety-critical applications (such as life support) where a failure of the TI product would reasonably be expected to cause severe personal injury or death, unless officers of the parties have executed an agreement specifically governing such use. Buyers represent that they have all necessary expertise in the safety and regulatory ramifications of their applications, and acknowledge and agree that they are solely responsible for all legal, regulatory and safety-related requirements concerning their products and any use of TI products in such safety-critical applications, notwithstanding any applications-related information or support that may be provided by TI. Further, Buyers must fully indemnify TI and its representatives against any damages arising out of the use of TI products in such safety-critical applications.

TI products are neither designed nor intended for use in military/aerospace applications or environments unless the TI products are specifically designated by TI as military-grade or "enhanced plastic." Only products designated by TI as military-grade meet military specifications. Buyers acknowledge and agree that any such use of TI products which TI has not designated as military-grade is solely at the Buyer's risk, and that they are solely responsible for compliance with all legal and regulatory requirements in connection with such use.

TI products are neither designed nor intended for use in automotive applications or environments unless the specific TI products are designated by TI as compliant with ISO/TS 16949 requirements. Buyers acknowledge and agree that, if they use any non-designated products in automotive applications, TI will not be responsible for any failure to meet such requirements.

Following are URLs where you can obtain information on other Texas Instruments products and application solutions:

Products

Audio	www.ti.com/audio
Amplifiers	amplifier.ti.com
Data Converters	dataconverter.ti.com
DLP® Products	www.dlp.com
DSP	dsp.ti.com
Clocks and Timers	www.ti.com/clocks
Interface	interface.ti.com
Logic	logic.ti.com
Power Mgmt	power.ti.com
Microcontrollers	microcontroller.ti.com
RFID	www.ti-rfid.com
RF/IF and ZigBee® Solutions	www.ti.com/lprf

Applications

Communications and Telecom	www.ti.com/communications
Computers and Peripherals	www.ti.com/computers
Consumer Electronics	www.ti.com/consumer-apps
Energy and Lighting	www.ti.com/energy
Industrial	www.ti.com/industrial
Medical	www.ti.com/medical
Security	www.ti.com/security
Space, Avionics and Defense	www.ti.com/space-avionics-defense
Transportation and Automotive	www.ti.com/automotive
Video and Imaging	www.ti.com/video
Wireless	www.ti.com/wireless-apps

TI E2E Community Home Page

e2e.ti.com

Mailing Address: Texas Instruments, Post Office Box 655303, Dallas, Texas 75265
Copyright © 2011, Texas Instruments Incorporated